

Operating Instructions

Reflex Light Barriers

JP705 Ex

JP7051 Ex

for Hazardous Areas

,41302.pdf

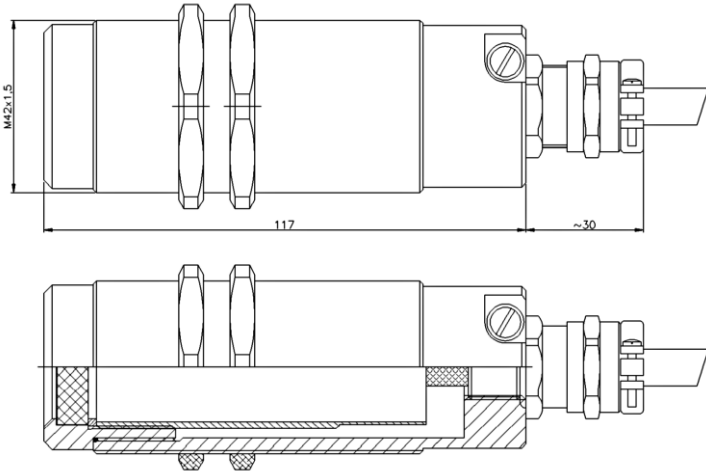
Features	Applications
<ul style="list-style-type: none"> ✓ Large working range – typically up to 20 m in very dusty environments ✓ Explosion-proof reflex light barrier ✓ II 2G Ex d IIC T6 Gb ✓ II 2D Ex tb IIIC T80°C Db IP66 	<ul style="list-style-type: none"> ○ Detection of material / objects in hazardous areas in Zone 1 or Zone 21 <div style="text-align: center; margin-top: 20px;">  <p>JP705 Ex / JP7051 Ex reflex light barrier</p> </div>
 <p>Sketch of JP705 Ex / JP7051 Ex</p>	

Revision Status: 2017-11
 Edited: 24.08.17 tb

Table of Contents

1 Identification	3
1.1 Product Brand	3
1.2 Product Versions / Marking	3
1.3 Name and Address of the Manufacturing Company	3
1.4 Declaration of Conformity	3
2 Product Description	4
2.1 General Functions and Range of Applications, Use in Accordance with the Intended Purpose	4
2.2 Dimensions and Weight (for transport purposes)	4
2.3 IP Code	5
2.4 Ambient Conditions and Limits for Operation and Storage	5
2.5 Safety information, summary (use for purposes other than those intended)	5
3 Definitions – Technical Data	6
4 Preparing the Product for Use	6
5 Connection	6
5.1 Wiring the Reflex Light Barrier	6
5.2 PE Connection at the Reflex Light Barrier	7
6 Marking the Light Barriers	7
7 Maintenance and Cleaning	8
8 Spare Parts List	8
9 Decommissioning the Product	8
10 Annex – Supplementary Documents	8

1 Identification

1.1 Product Brand	“JP705... Ex” reflex light barrier for hazardous areas
1.2 Product Versions / Marking	Infrared light : JP705 Ex Red light : JP7051 Ex
1.3 Name and Address of the Manufacturing Company	Fotoelektrik Pauly GmbH Wahrbrink 6, 59368 Werne, Germany
1.4 Declaration of Conformity	The above products were developed and manufactured in conformance to the following standards or normative documents!

- Low-voltage directive 2014/35/EU
- EMC directive 2014/30/EU
- ATEX directive 2014/34/EU

EC-Type Examination Certificate of Equipment and Components for Use in Hazardous Areas (Directive 94/9/EC):

Certificate No.: **BVS 08 ATEX E 122**

Marking:  II 2G Ex d IIC T6 Gb
II 2D Ex tb IIIC T80°C Db IP66

IECEX Certificate of Conformity, IEC Certification Scheme for Explosive Atmospheres:

Certificate No.: **IECEX BVS 12.0029X**

Marking: Ex d IIC T6 Gb
Ex tb IIIC T80°C Db IP66

Applied Standards and Technical Specifications:

IEC 60079-0:2011, modified General Requirements
+ Cor.:2012 + Cor.:2013

IEC 60079-1:2014 Equipment protection flameproof enclosure “d”

IEC 60079-31:2013 Equipment dust ignition protection by enclosure “t”

2 Product Description

2.1 General Functions and Range of Applications, Use in Accordance with the Intended Purpose

The “JP705... Ex” reflex light barrier was developed for use in hazardous areas in Zone 1 and Zone 21.

The “JP705... Ex” reflex light barrier consists of a transmitter and a receiver. The transmitter and receiver electronics are fitted onto a joint printed circuit board. The printed circuit board is accommodated in a flameproof enclosure. The transmitting and receiving beam is formed to produce a joint overlapping area. A reflector that is positioned inside this beam overlapping area is illuminated and observed at the same time. The reflection causes the receiver to respond.

When 24VDC supply voltage is applied, the transmitter light is switched on and the receiver is in direct receiving readiness. A modulated light signal is generated by the transmitter. The type “JP705/yL Ex” works with the invisible infra-red light. The JP7051 Ex type works with visible red light. The transmitted light signal has a defined clock ratio. The receiver sees the modulated light transmitted by the transmitter and reflected by the reflector. The switching output in the receiver is switched on or off according to the selected signal mode – bright-switching or dark-switching.

When the “bright-switching” signal mode is selected, the transistor is switched on when the light path between the reflex light barrier and the reflector is unobstructed.

When the “dark-switching” signal mode is selected, the transistor is switched on if the light path between the reflex light barrier and reflector is completely obstructed.

When switched on, the switching output supplies a voltage potential of 24VDC. When switched off, the P-N-P transistor provides a high level of impedance.

The switching state of the reflex light barrier is typically evaluated with a PLC or a monitoring device. Depending on the logical operator, it may be necessary to have pull-up or pull-down resistance.

The reflex light barrier is designed for working ranges of up to 20 m, depending on the reflector. The reflex light barrier can be used for tracking materials or detecting the presence of an object in very many different automated industrial applications.

2.2 Dimensions and Weight (for transport purposes)

Designation	Type	Dimensions	Weight
Infra-red light reflex light barrier	JP705 Ex	M42 x 147mm	approx. 1500 g (incl. 5 m cable)
Red light reflex light barrier	JP7051 Ex	M42 x 147mm	approx. 1500 g (incl. 5 m cable)

2.3 IP Code

Designation	Type	IP Code
Infrared light reflex light barrier	JP705 Ex	IP66 – Protection against Dust and Powerful Water Jets
Red light reflex light barrier	JP7051 Ex	IP66 – Protection against Dust and Powerful Water Jets

The cable entry used at the transmitters and receivers determines whether or not the entire enclosure conforms to the IP protection. Only the cable entries with “M16 x 1.5” threading, included in the scope of supply, may be used.

2.4 Ambient Conditions and Limits for Operation and Storage

Ambient temperature ($T_{amb.}$): -20 °C to +60 °C
Storage temperature: -20 °C to +70 °C

2.5 Safety information, summary (use for purposes other than those intended)



The owner / managing operator / installer must acquire information about the Ex regulations that apply to his area of application and conform to these regulations. The same applies when cables and conductors are being installed and wired. In applications in Zone 21 it must be ensured when installing the connection cable that electrostatic charging cannot lead to ignitable discharges.



When plastic reflectors are used, the projected area must be less or equal to 20 cm². The requirements of EN 13463-1 must be observed.



When plastic reflectors with an area greater than 20 cm² and less than or equal to 80 cm² are used, the exposed plastic surfaces must be surrounded by a conductive earthed frame. The requirements of EN 13463-1 must be observed.



The light barrier and the reflector may be installed only by an authorised and qualified person with the specialist knowledge required for the installation of electrical equipment in hazardous areas.



The requirements of EN 60079-0 and EN 60079-1 must be observed.



The reflex light barrier may not be dismantled.



If connecting in a hazardous area:
the connection cable for the transmitter and receiver must be connected in an enclosure. The enclosure used must meet the requirements of a recognised type of protection (complying with EN60079-0, Section 1.2).



If the enclosure or cable entry is damaged or no longer leak-tight, the device must be put out of operation.



External sources that radiate heat or cold and could impermissibly heat or cool the surfaces of the device are prohibited and special care must be taken to prevent them occurring.

3 Definitions – Technical Data

(See enclosed data sheet in the annex for a precise specifications)

Reflex light barrier	JP705 Ex	JP7051 Ex
Enclosure Material:	VA	
Dimensions:	M42x1.5 x 147 mm	
Voltage supply	24VDC	
Power consumption	40mA / <1W without load	
Connection	No. cable 4x0.75mm ² shielded (typical length 5 m)	
Ambient temperature	-20 to +60 °C	
Emitted light	LED 880 nm, invisible	LED 650 nm, visible
Switching output receiver	P-N-P transistor, short-circuit proof 60 mA (Optional: N-P-N transistor, short-circuit proof 60 mA)	
Signal mode	Bright-switching (Optional: dark-switching)	
Switch indicator	Green LED	
Ambient temperature	-20 to +60 °C	
Steady light resistance	> 80 kLux	
Access time	< 12ms/switch transition	
Interference suppression	Forced synchronisation	
Reflector	Reflectors in accordance with data sheet	

4 Preparing the Product for Use

Reflex light barrier and reflector must be mounted opposite each other.

The objects to be monitored must be able to fully occupy the light path between the reflex light barrier and the reflector.

When installing, observe the following operating instructions and the data sheets in the annex.

5 Connection

5.1 Wiring the Reflex Light Barrier

The JP705 Ex and JP7051 Ex reflex light barrier must be wired in accordance with the data sheet.

5.2 PE Connection at the Reflex Light Barrier

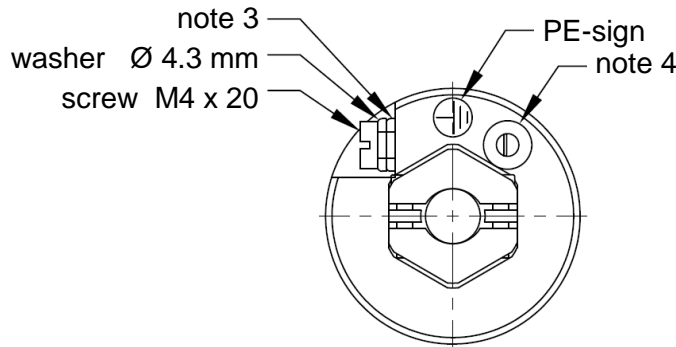

Note 3: Connection for cable lug with ring eyelet, internal diameter 4.3 mm, External diameter maximum of 9.5mm.

Note 4: Connection for rigid wire from 0.5 to 6mm² or flexible wire with wire end ferrule of 0.5 to 4mm².



Only one of the two connection possibilities may be used, either that described in note 3 or in note 4!

Equipotential Bonding at the Reflector

When using reflectors with an exposed plastic surface of 20 cm² to 80 cm², the frame must be fastened in an electrically conductive manner to the earthed site of installation. In insulated assembly the reflector must be connected to an equipotential bonding conductor.

6 Marking the Light Barriers

The reflex light barrier must be marked with the following stickers.

Reflex light barrier:
JP705 Ex

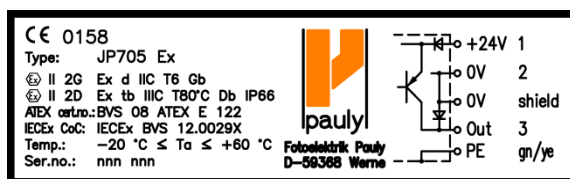

Reflex light barrier:
JP7051 Ex

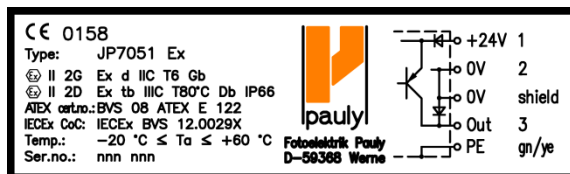

7 Maintenance and Cleaning

- ❖ Maintenance and cleaning work may be done only by qualified personnel who are familiar with the location and have received the relevant instructions.
- ❖ Only a damp cloth may be used to clean the viewing glass. Do not use any aggressive cleaning agents!
- ❖ If the enclosure or cable entry is damaged or no longer leak-tight, the device must be put out of operation.
- ❖ Repairs to the device itself may be done only by the manufacturing company itself.

8 Spare Parts List

Designation	Type	Version	Order Code
Infra-red light reflex light barrier	JP705 Ex	/e2/5mK4/ir/24VDC [/h] OR [/d]	4130
Red light reflex light barrier	JP7051 Ex	/e2/5mK4/rl/24VDC [/h] OR [/d]	4130M01

For order enquiries the type, version and order code must be specified.

9 Decommissioning the Product

- ❖ The product may be decommissioned only by qualified personnel who are familiar with the location and have received the relevant instructions.

10 Annex – Supplementary Documents

Data sheet	(Infra-)red light reflex light barrier	E_41301	2017-08-24
------------	--	---------	------------

D-59368 Werne, 2017-08-24

* 41302 GE *

Fotoelektrik Pauly GmbH

The design and make of the devices and their electronics are the intellectual property of the company "Fotoelektrik Pauly GmbH". Accordingly, for copyright reasons, internal circuit diagrams cannot be handed over. Subject to technical alterations. Errors excepted. The reprinting of this document or the copying of extracts from it is allowed only with the approval of "Fotoelektrik Pauly GmbH" and with an indication of the sources used. Infringements are punishable by law.